



unmontiert



### Werkstoff

Stahl 1.2379

### Hinweis

das unmontierte Modul wird als Baukasten geliefert; es beinhaltet die dazugehörige Rahmen-, Führungs-, Zwischen-, Halte-, Druckplatten und die Baugruppe Führungseinheit und Zubehör

b	l	Anzahl Führungen	Artikelnummer
200	100	2	ST0900 <b>100 x 200</b>
	150	2	ST0900 <b>150 x 200</b>
	200	4	ST0900 <b>200 x 200</b>
	250	4	ST0900 <b>250 x 200</b>
	300	4	ST0900 <b>300 x 200</b>
	350	4	ST0900 <b>350 x 200</b>
250	100	2	ST0900 <b>100 x 250</b>
	150	2	ST0900 <b>150 x 250</b>
	200	4	ST0900 <b>200 x 250</b>
	250	4	ST0900 <b>250 x 250</b>
	300	4	ST0900 <b>300 x 250</b>
	350	4	ST0900 <b>350 x 250</b>

montiert

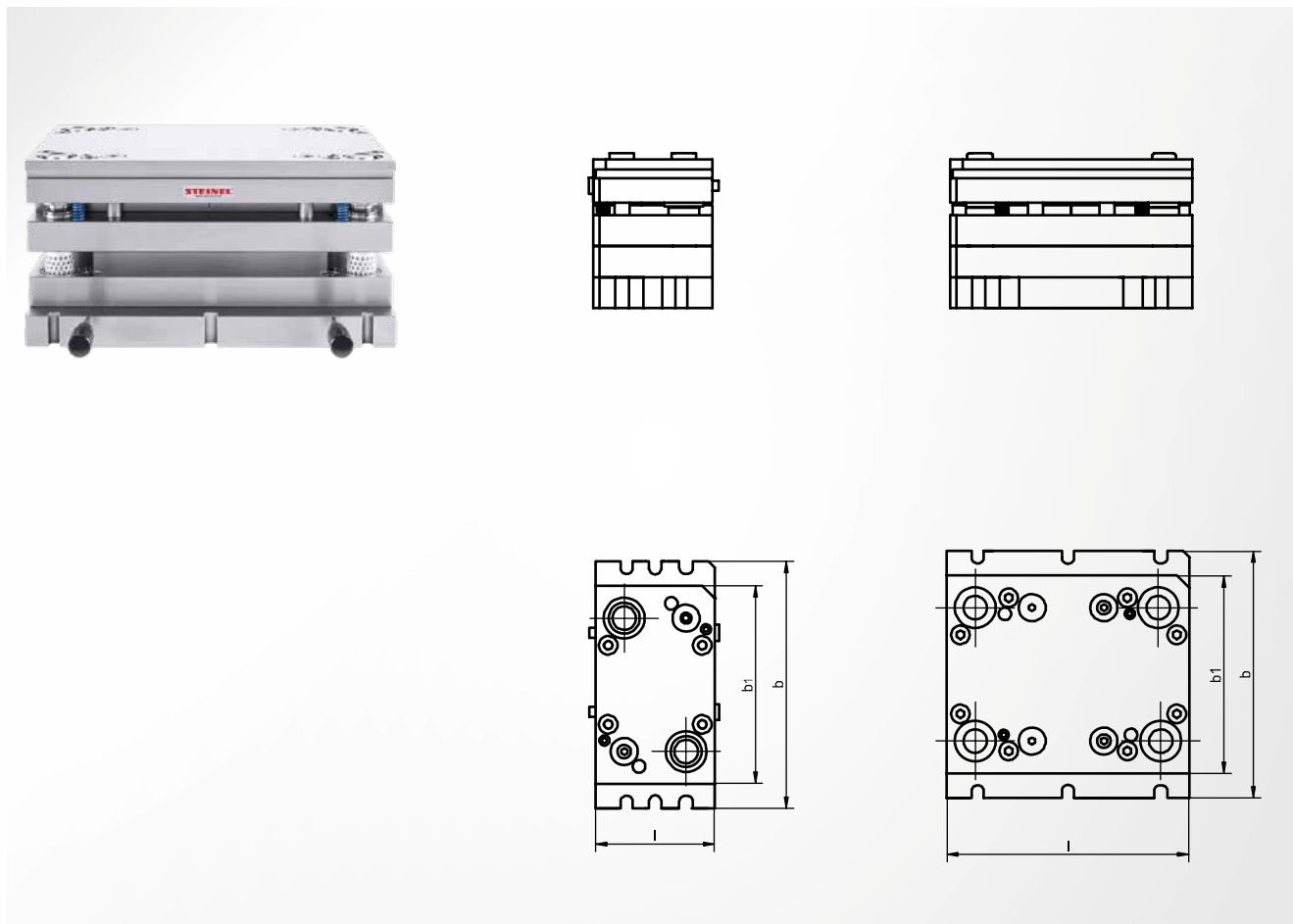

## Werkstoff

Stahl 1.2379

b	b <sub>1</sub>	l	Anzahl Führungen	Artikelnummer
200	150	100	2	ST0901 <b>100 x 200</b>
		150	2	ST0901 <b>150 x 200</b>
		200	4	ST0901 <b>200 x 200</b>
		250	4	ST0901 <b>250 x 200</b>
		300	4	ST0901 <b>300 x 200</b>
		350	4	ST0901 <b>350 x 200</b>
250	200	100	2	ST0901 <b>100 x 250</b>
		150	2	ST0901 <b>150 x 250</b>
		200	4	ST0901 <b>200 x 250</b>
		250	4	ST0901 <b>250 x 250</b>
		300	4	ST0901 <b>300 x 250</b>
		350	4	ST0901 <b>350 x 250</b>

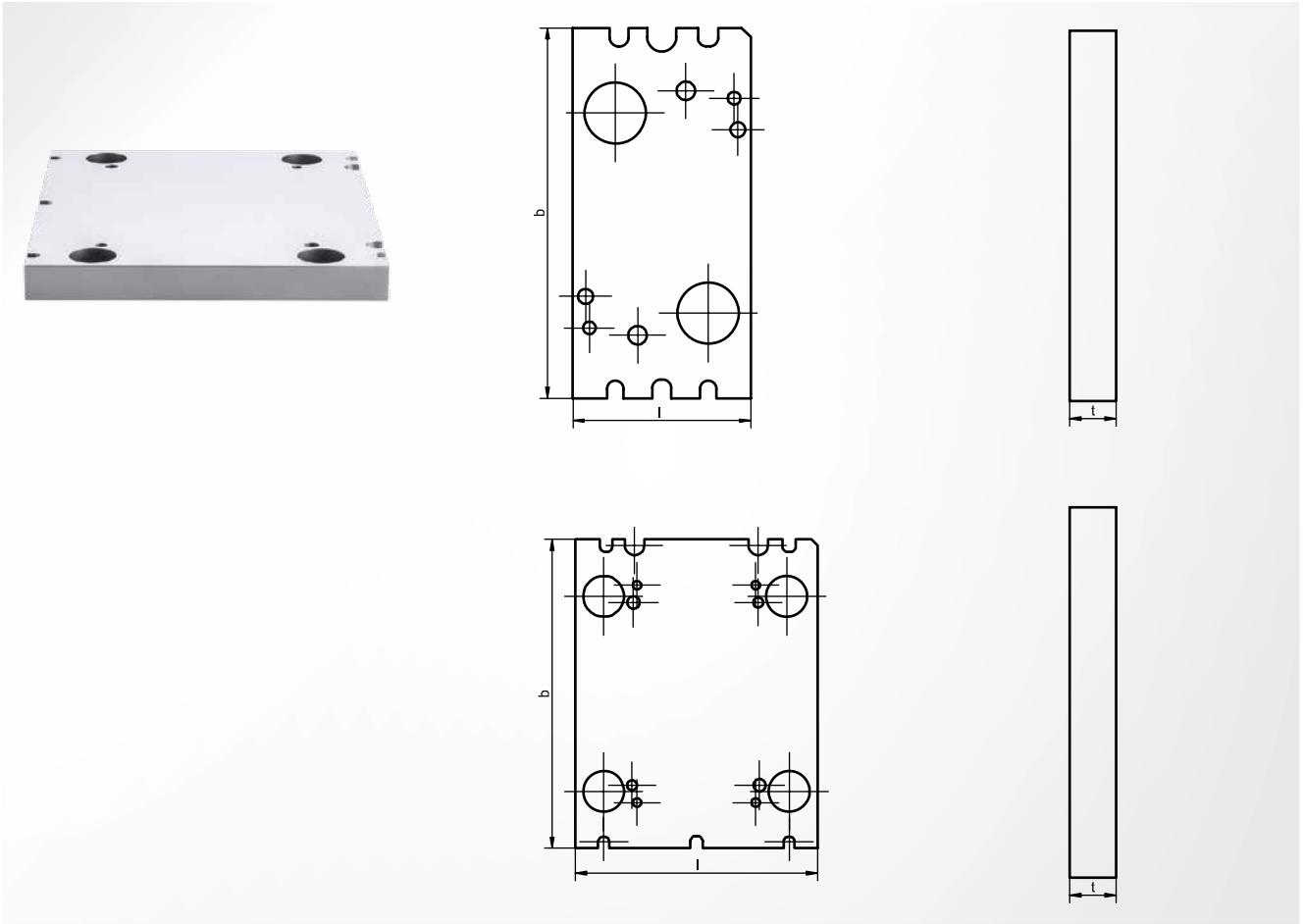

**Werkstoff**

Stahl 1.2379

**Härte**

58+2 HRC

b	l	t	Artikelnummer
200	100	25	ST0900 <b>100 x 200-01</b>
	150	25	ST0900 <b>150 x 200-01</b>
	200	25	ST0900 <b>200 x 200-01</b>
	250	25	ST0900 <b>250 x 200-01</b>
	300	25	ST0900 <b>300 x 200-01</b>
	350	25	ST0900 <b>350 x 200-01</b>
250	100	25	ST0900 <b>100 x 250-01</b>
	150	25	ST0900 <b>150 x 250-01</b>
	200	25	ST0900 <b>200 x 250-01</b>
	250	25	ST0900 <b>250 x 250-01</b>
	300	25	ST0900 <b>300 x 250-01</b>
	350	25	ST0900 <b>350 x 250-01</b>

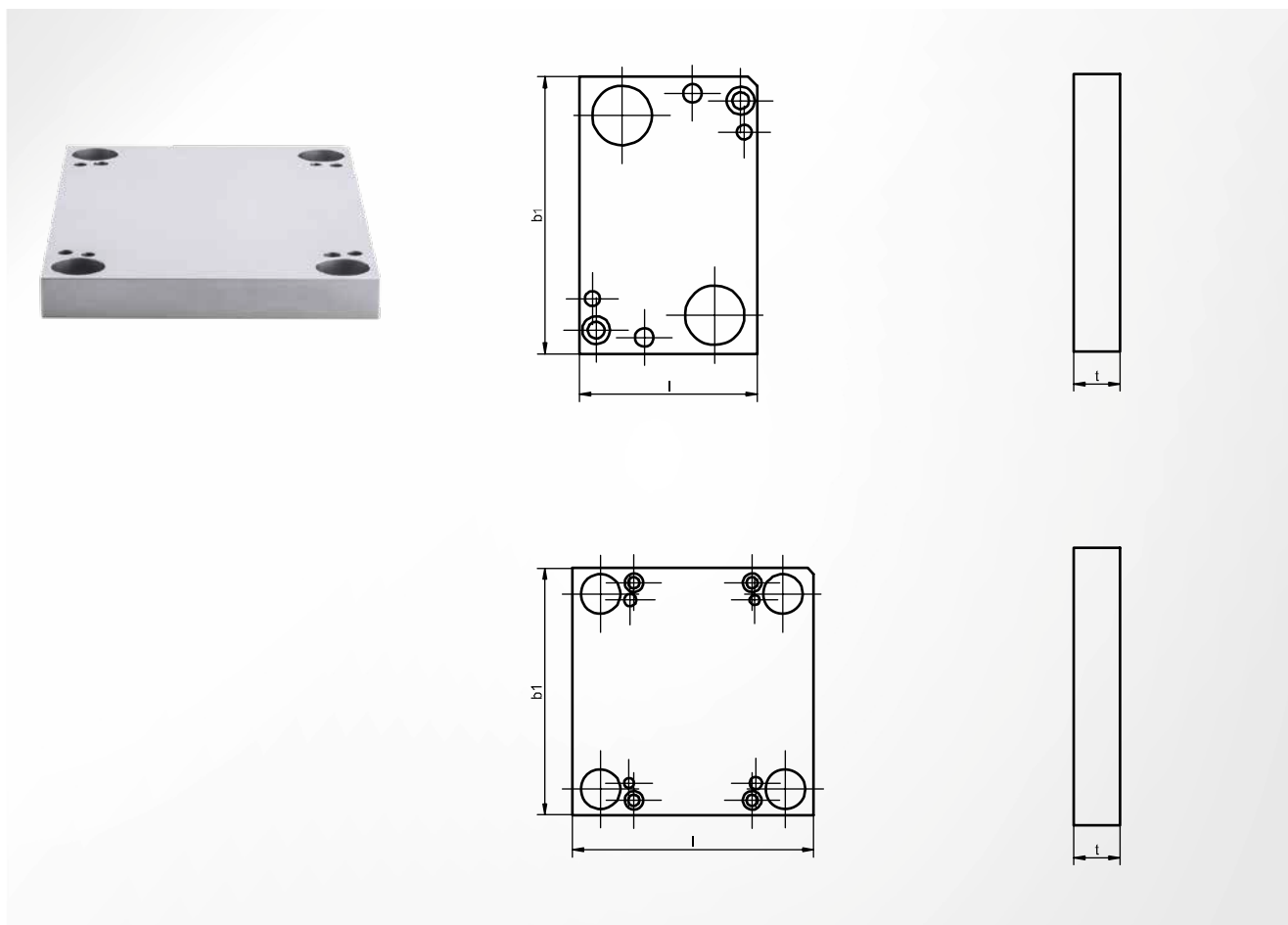

### Werkstoff

Stahl 1.2379; extra gefrostet

### Härte

58+2 HRC

b	b <sub>1</sub>	l	t	Artikelnummer
200	150	100	25	ST0900 <b>100 x 200-02</b>
		150	25	ST0900 <b>150 x 200-02</b>
		200	25	ST0900 <b>200 x 200-02</b>
		250	25	ST0900 <b>250 x 200-02</b>
		300	25	ST0900 <b>300 x 200-02</b>
		350	25	ST0900 <b>350 x 200-02</b>
250	200	100	25	ST0900 <b>100 x 250-02</b>
		150	25	ST0900 <b>150 x 250-02</b>
		200	25	ST0900 <b>200 x 250-02</b>
		250	25	ST0900 <b>250 x 250-02</b>
		300	25	ST0900 <b>300 x 250-02</b>
		350	25	ST0900 <b>350 x 250-02</b>

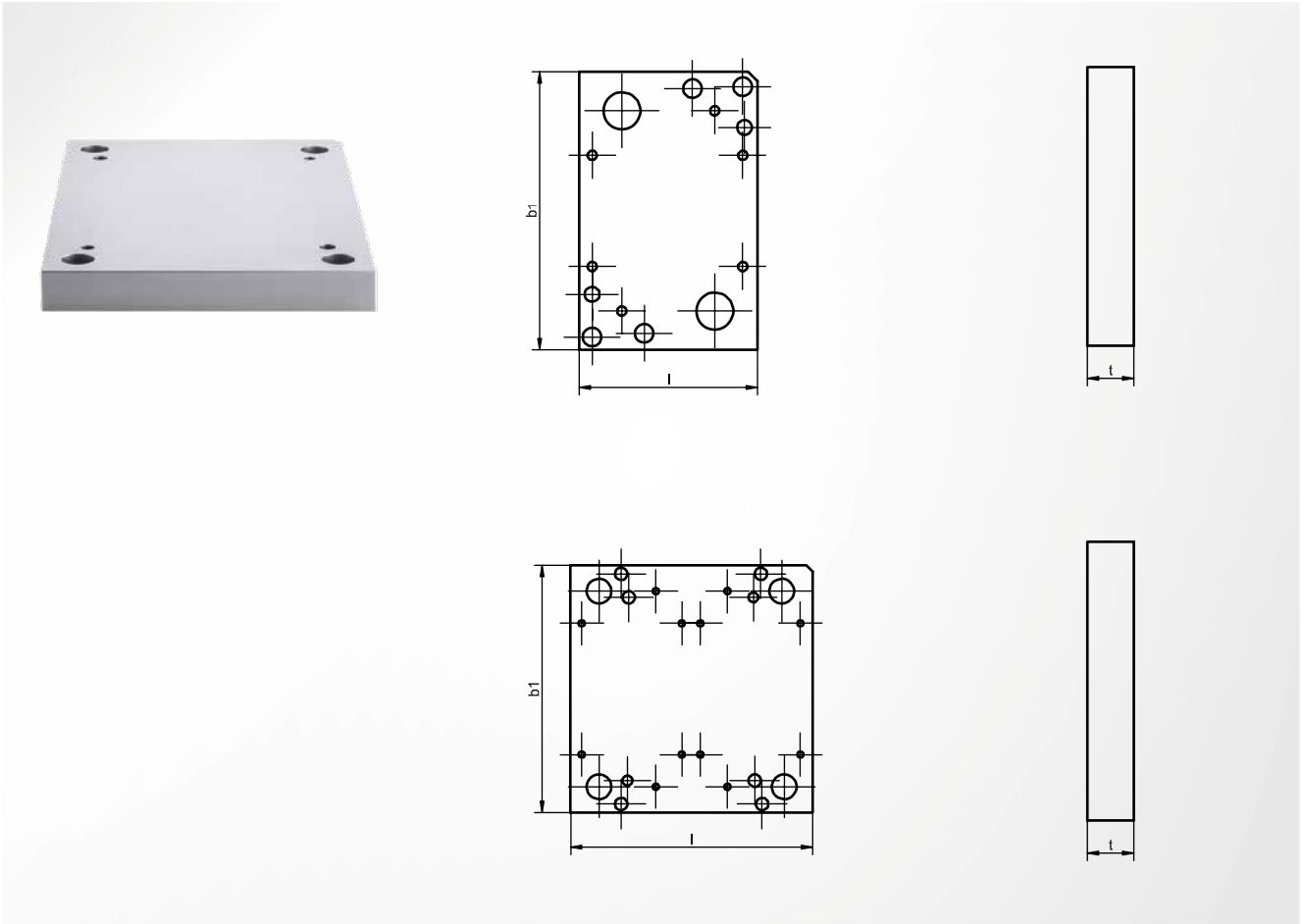

### Werkstoff

Stahl 1.2379; extra gefrostet

### Härte

58+2 HRC

b	b <sub>1</sub>	l	t	Artikelnummer
200	150	100	25	ST0900 <b>100 x 200-03</b>
		150	25	ST0900 <b>150 x 200-03</b>
		200	25	ST0900 <b>200 x 200-03</b>
		250	25	ST0900 <b>250 x 200-03</b>
		300	25	ST0900 <b>300 x 200-03</b>
		350	25	ST0900 <b>350 x 200-03</b>
250	200	100	25	ST0900 <b>100 x 250-03</b>
		150	25	ST0900 <b>150 x 250-03</b>
		200	25	ST0900 <b>200 x 250-03</b>
		250	25	ST0900 <b>250 x 250-03</b>
		300	25	ST0900 <b>300 x 250-03</b>
		350	25	ST0900 <b>350 x 250-03</b>

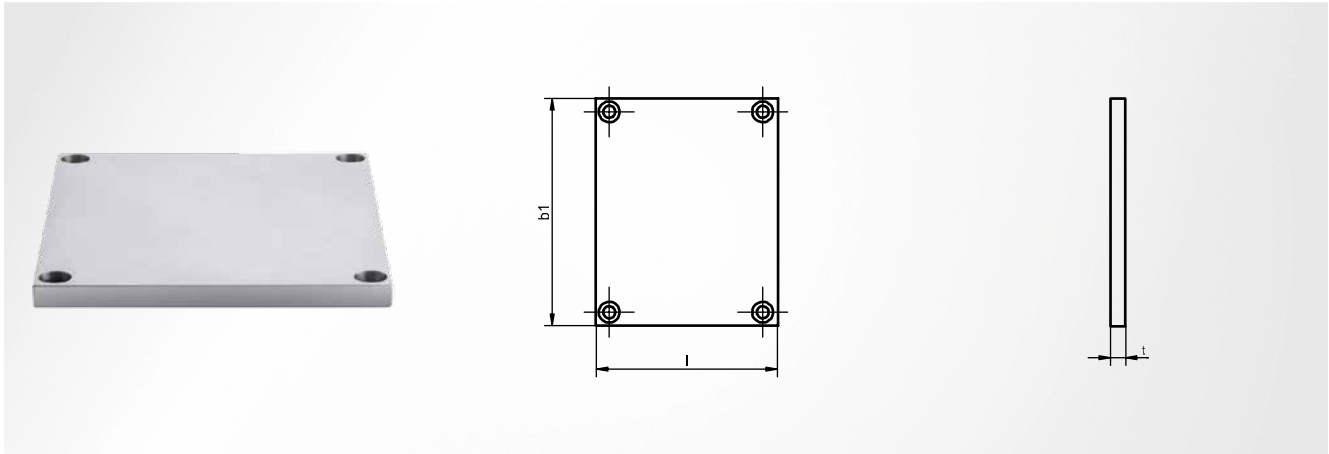

## Werkstoff

Stahl 1.2379

b	b <sub>1</sub>	l	t	Artikelnummer
200	74	100	8	ST0900 <b>100 x 200-04</b>
		150	8	ST0900 <b>150 x 200-07</b>
250	120	100	8	ST0900 <b>100 x 250-04</b>
		150	8	ST0900 <b>150 x 250-07</b>

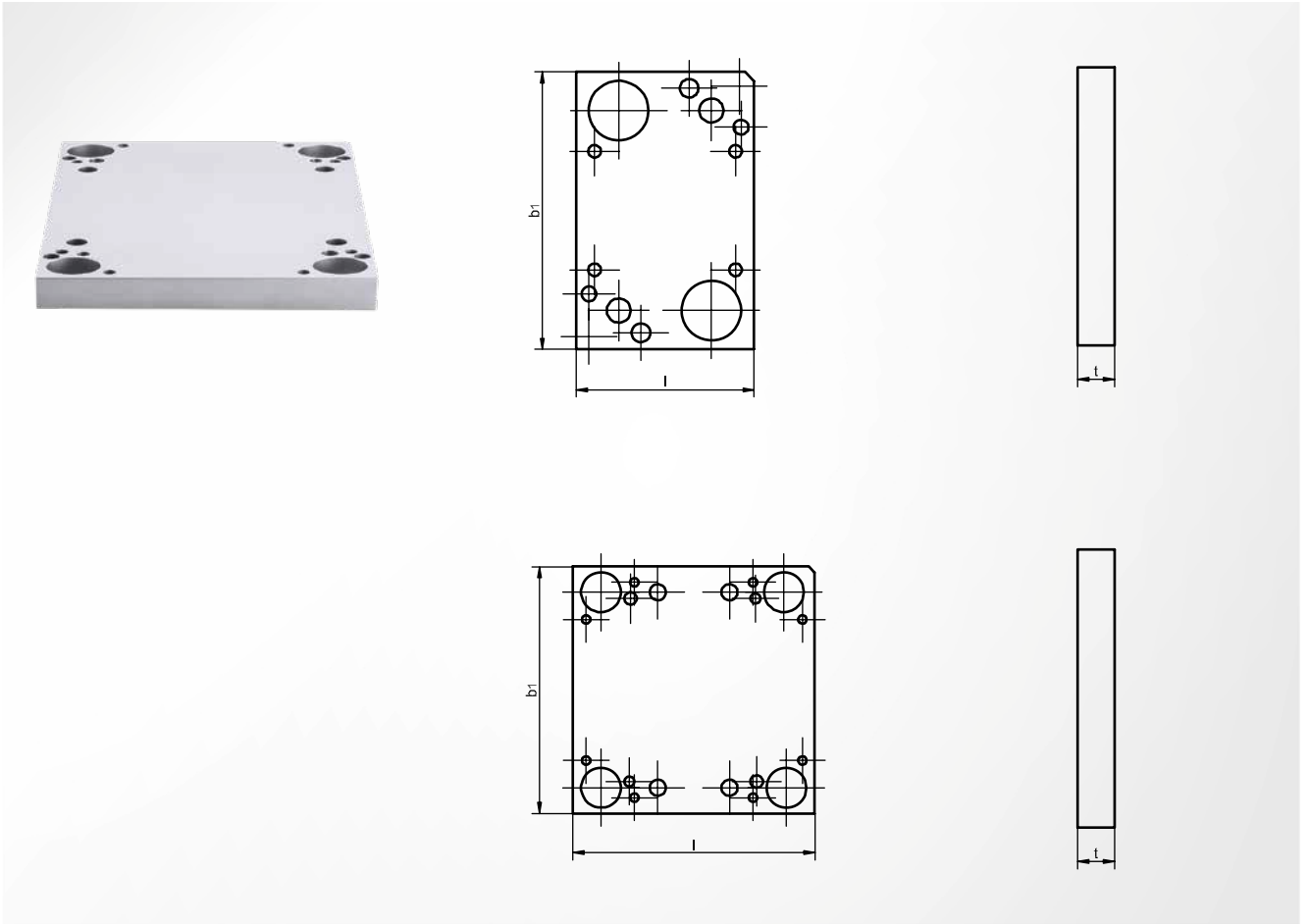

### Werkstoff

Stahl 1.2379; extra gefrostet

### Härte

58+2 HRC

b	b <sub>1</sub>	l	t	Artikelnummer
200	150	100	20	ST0900 <b>100 x 200-05</b>
		150	20	ST0900 <b>150 x 200-05</b>
		200	20	ST0900 <b>200 x 200-05</b>
		300	20	ST0900 <b>300 x 200-05</b>
		250	20	ST0900 <b>250 x 200-05</b>
		350	20	ST0900 <b>350 x 200-05</b>
250	200	100	20	ST0900 <b>100 x 250-05</b>
		150	20	ST0900 <b>150 x 250-05</b>
		200	20	ST0900 <b>200 x 250-05</b>
		250	20	ST0900 <b>250 x 250-05</b>
		300	20	ST0900 <b>300 x 250-05</b>
		350	20	ST0900 <b>350 x 250-05</b>



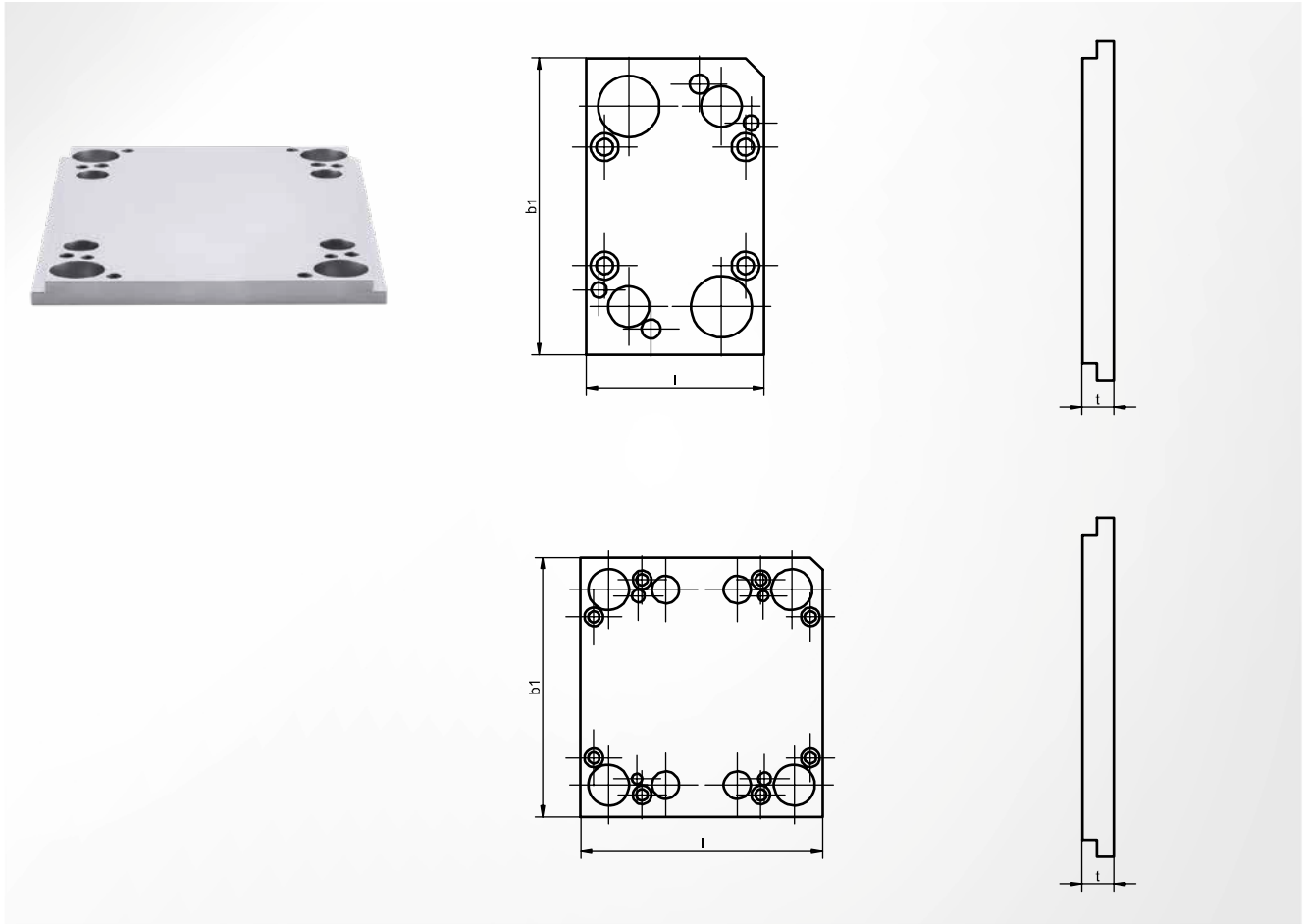

**Werkstoff**  
Stahl 1.2379

**Härte**  
58+2 HRC

b	b <sub>1</sub>	l	t	Artikelnummer
200	160	100	15	ST0900 <b>100 x 200-06</b>
		150	15	ST0900 <b>150 x 200-06</b>
		200	15	ST0900 <b>200 x 200-06</b>
		250	15	ST0900 <b>250 x 200-06</b>
		300	15	ST0900 <b>300 x 200-06</b>
		350	15	ST0900 <b>350 x 200-06</b>
250	210	200	15	ST0900 <b>200 x 250-06</b>
		100	15	ST0900 <b>100 x 250-06</b>
		150	15	ST0900 <b>150 x 250-06</b>
		250	15	ST0900 <b>250 x 250-06</b>
		300	15	ST0900 <b>300 x 250-06</b>
		350	15	ST0900 <b>350 x 250-06</b>

# ST0900-12 Führungseinheit

mit Mittenbund klein, glatt, Kugelführung Aluminium

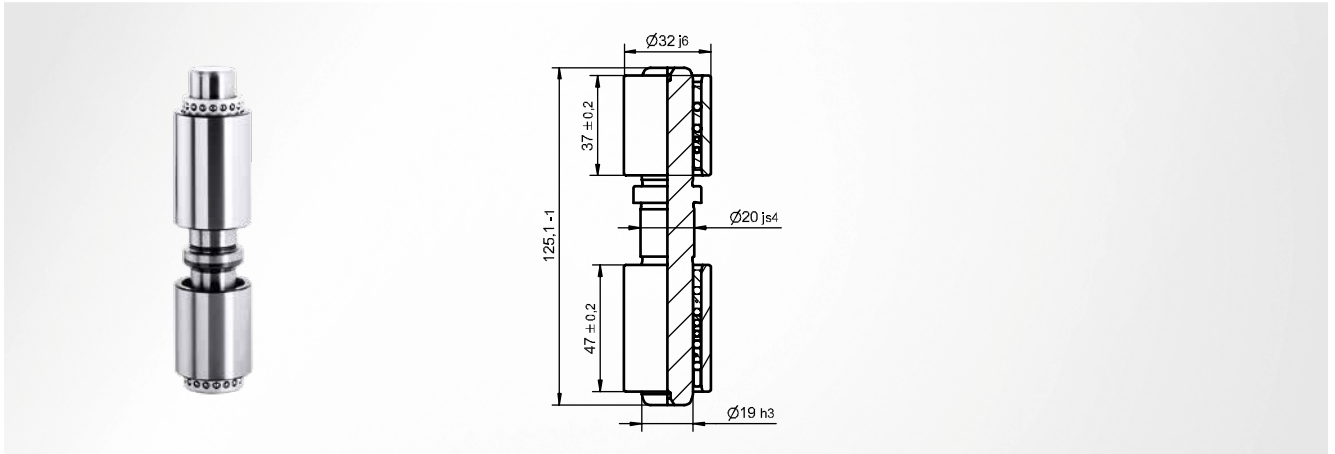

## Lieferumfang

ST740619X037; ST740619X047;  
ST717019X030; ST717019X043;  
ST0900711819X125

## Artikelnummer

ST0900-12